

MaxiLED
Lighting



MaxiPunch Static Series

KEY FEATURES

- 2700k - 5000k Colour Range (4k Standard)
- Excellent CRI (See Below)
- 3 Step Macadam Elise Colour Control
- Thermally Protected
- IP67
- Elegant Unit Design



Product Overview

The static MaxiPunch recessed static is elegant and in-keeping when installed on most landscapes, It's sleek design and IP67 rating is a must for most applications. The choice of LED colour temperatures, Beam angles and housing finishes allow designers worldwide to select their preferred combination.

Specifications

Electrical

Input Voltage:	220v - 240VAC
Frequency:	50/60 Hz
Amps:	0.9A
Power Factor:	0.80C
Power Consumption:	12W

Protection

Overload / Auto Recovery:	Yes
Thermal Shutdown:	Yes
Protection Rating:	IP67
Operating Temperature:	-20°C to +50°C (-4°F to +122°F)
Toughened Glass Lens:	Yes

LED Options

LED Manufacturer:	Cree
LED Colour options & CRI:	2700k (90), 3000k (90), 3500K (90) 4000k (80) <i>Standard</i> , 5000k (80).
LED current:	350mA
Lumens:	800 Lumens (4000k 80CRI)
Est. 85% Lumen Maintenance L70	
Predicted life (hours):	57,500 Hours
Photometrics available:	To follow
Binning:	3 step Macadam ellipse (2 step available on request for larger projects)

Optics

Beam Angles available:	12, 36, 60
------------------------	------------

Finishes

Black Anodised:	Yes
Silver Anodised:	Yes

Dimensions & Weights

Diameter (mm):	155mm
Depth (mm):	60.5mm
Weight (kg):	1.78kg

Fitting option:	Recessed sleeve
------------------------	-----------------

Material:	Aluminium / Stainless steel (on request)
------------------	--

Listings:

Safety:	CE
EMC Compliance:	EN55015, EN61457, EN61000-3-2, EN61000-3-3



UK Designed and
Manufactured

MaxiLED Lighting

Unit 2, Farrington Place, Rossendale Road Ind. Est. Burnley, Lancashire. UK. BB11 5TY

T: +44 (0)845 8732 601 F: +44 (0)845 8732 602

E: sales@maxiledlighting.com Web: www.maxiledlighting.com

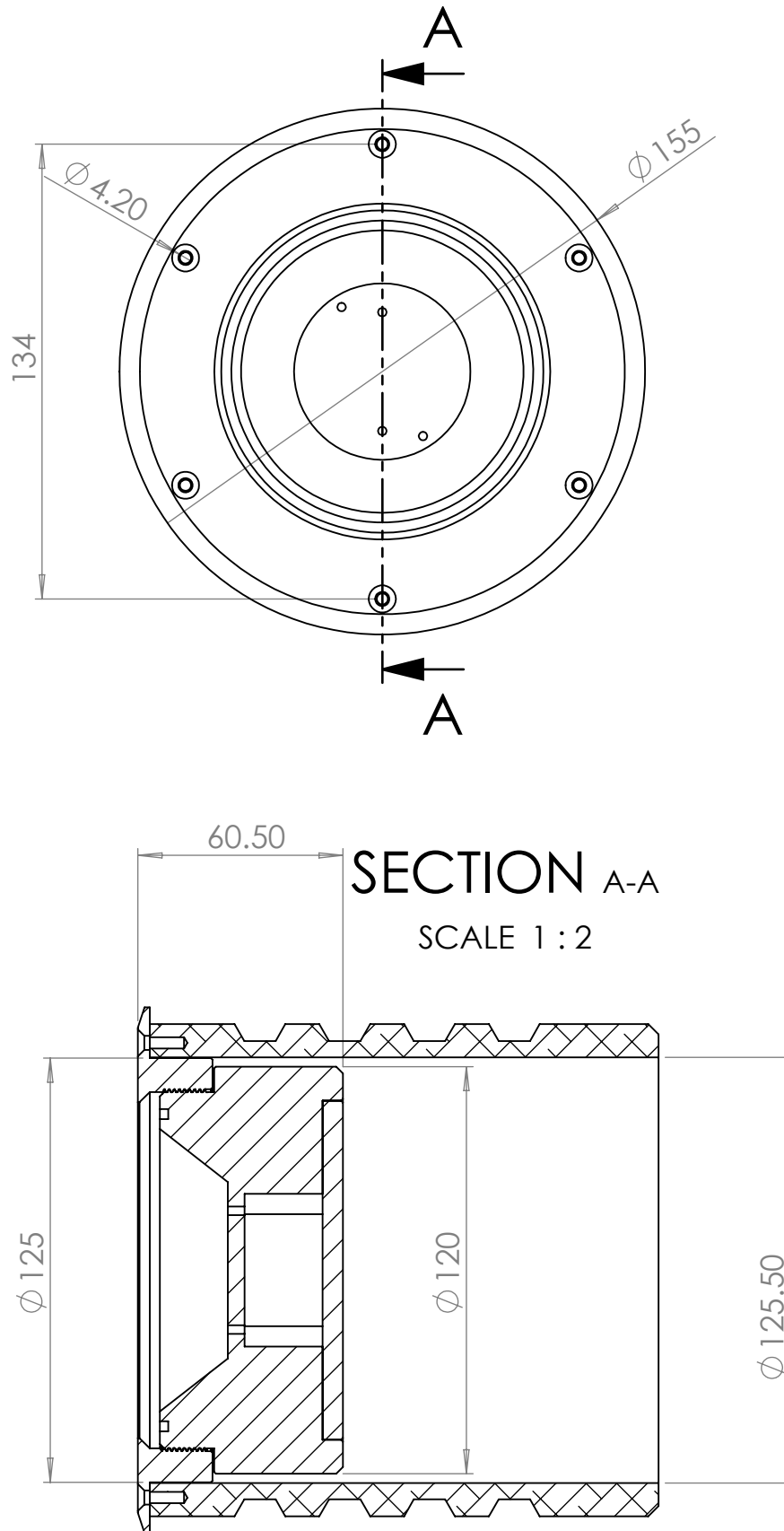

MaxiLED Lighting

Unit 2, Farrington Place, Rossendale Road Ind. Est. Burnley, Lancashire. UK. BB11 5TY

T: +44 (0)845 8732 601 F: +44 (0)845 8732 602

E: sales@maxiledlighting.com Web: www.maxiledlighting.com