

## WARNING: ONLY 48V / DATA MAXILINK ONLY



This product must be installed by a qualified electrician in accordance with all national and local electrical and construction codes.  
Failure to comply with the installation instructions can result in serious injury or death.



### 1 Preparing Ground Work

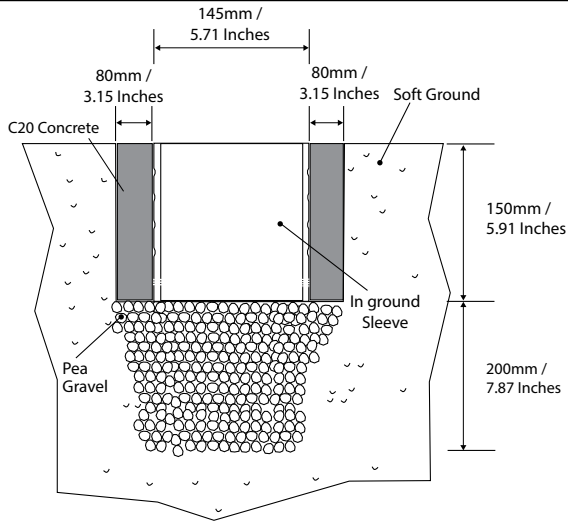

- Prepare ground work. Trench minimum 350mm / 14 Inches deep.
- Fill lower half with pea gravel for drainage.
- Place In ground sleeve flush with ground.
- Add C20 Concrete.

Always prepare 30cm of drainage gravel. Fill the installation sleeve with water and check that it completely drains within 30mins. If not find a further drainage solution.

### 2 Sleeve Orientation

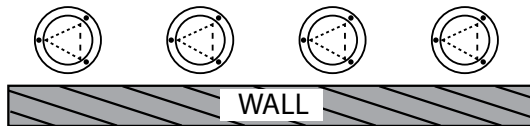

#### NOTE:

- Make sure sleeve holes are all aligned so that the fittings will be uniform after final installation. (Illustration for MaxiPUNCH 302)

### 3 Make connections using IP68 junction box

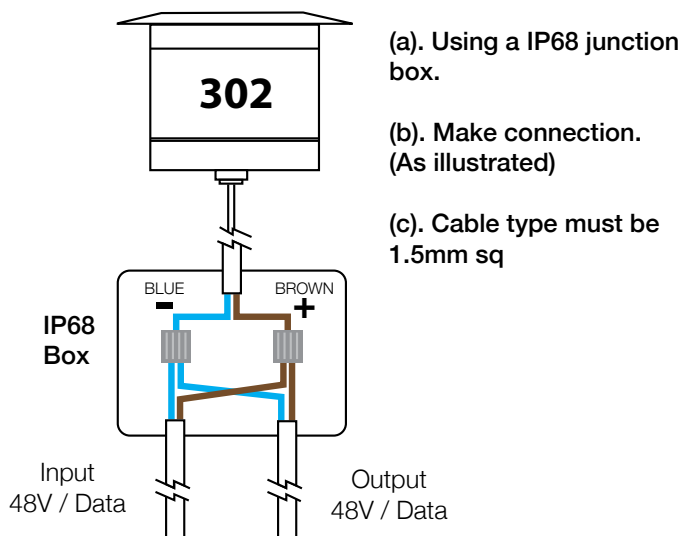

### 4 Final fitting

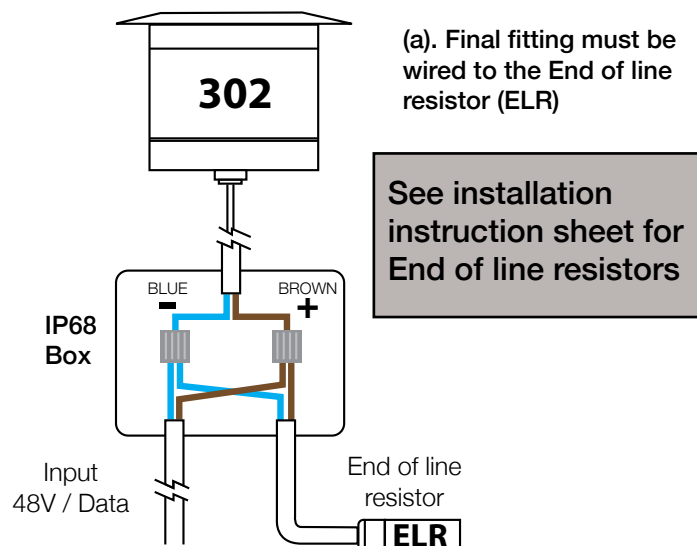

See installation instruction sheet for End of line resistors