

WARNING: ONLY 48V / DATA MAXILINK ONLY



This product must be installed by a qualified electrician in accordance with all national and local electrical and construction codes.
Failure to comply with the installation instructions can result in serious injury or death.



1 Preparing Ground Work

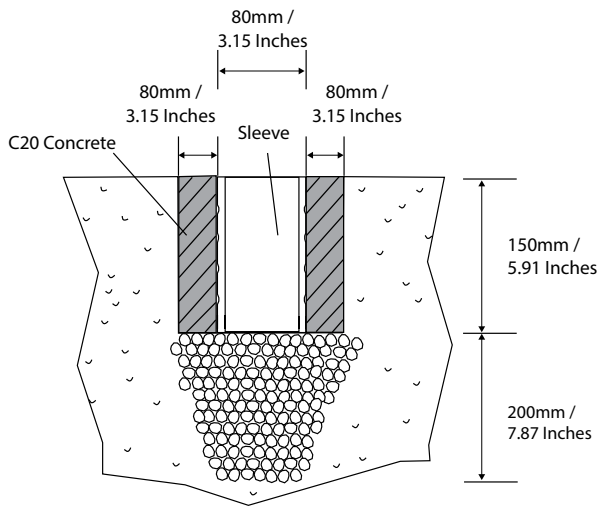

- Prepare ground work.
Trench minimum 350mm / 14 Inches deep.
- Fill lower half with pea gravel for drainage.
- Place In ground sleeve flush with ground.
- Add C20 Concrete.

Always prepare 30cm of drainage gravel. Fill the installation sleeve with water and check that it completely drains within 30mins.
If not find a further drainage solution.

2 Sleeve Orientation

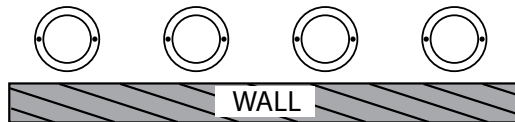

NOTE:

- Make sure sleeve holes are all aligned so that the fittings will be uniform after final installation.
(Illustration for MaxiDEPTH 102)

3 Make connections using IP68 junction box

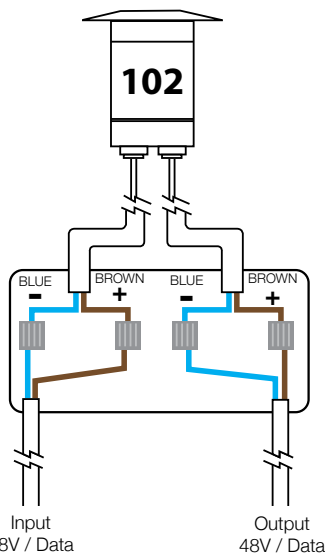

- Using a minimum IP68 submersible joint inline with local authority regulations
- Make connection.
(As illustrated)
- Cable type must be 1.5mm sq

4 Final fitting

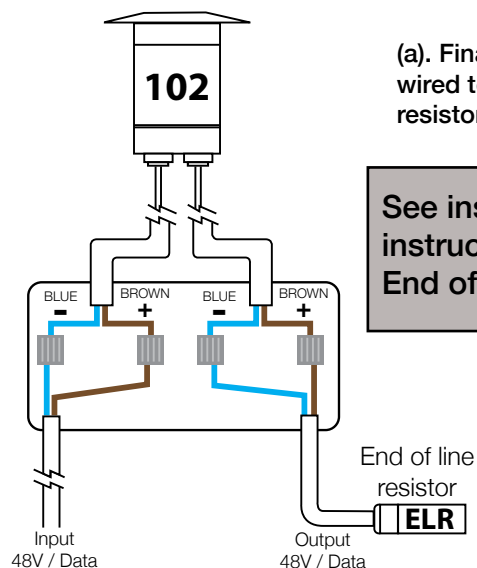

- Final fitting must be wired to the End of line resistor (ELR)

See installation instruction sheet for End of line resistors